

SW[®] Automatic Air Vent Valve

Stainless Steel 304/316 Air Vent Valve

Application:

The automatic air vent valves are usually used in HVAC, solar system, floor heating system, chemical equipment, wind power system, and so on.

Feature:

All the valves have been tested prior to shipment; ensure that the valves only exhaust air during working.

The valves will work to protect system when there are bubbles.

Technical Parameters:

Operating pressure: 0.1 ~ 25 Bar.

Operating temperature: FKM Sealing: -20 ~ 180°C, EPDM Sealing: -40 ~ 110°C.

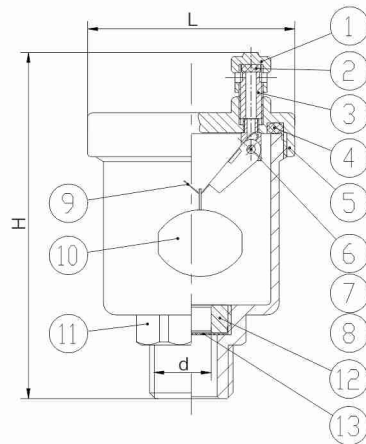

Dimension

SIZE	L	H	d
3/8"	52	87	8
1/2"	52	88	10
3/4"	52	91	15
1"	52	93	22

Unit:mm

General material

No.	Name	262
1	Cap	SS304
2	Gasket	FKM/EPDM
3	Exhaust Column	SS304
4	O-ring	FKM/EPDM
5	Bonnet	SS304/SS316
6	Sealing Column	SS304/SS316
7	Balancing Column	SS304/SS316
8	Gasket	FKM/EPDM
9	Bouncing Slince	SS304/SS316
10	Float	SS304/SS316
11	Valve Body	SS304/SS316
12	Locked Nut	SS304
13	Strainer	SS304