

## 100X Float Ball Valve

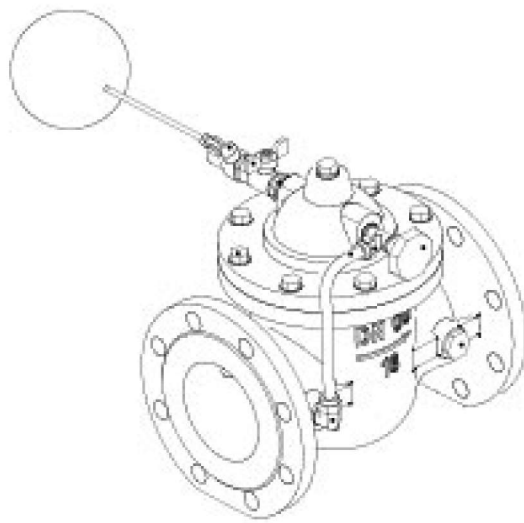
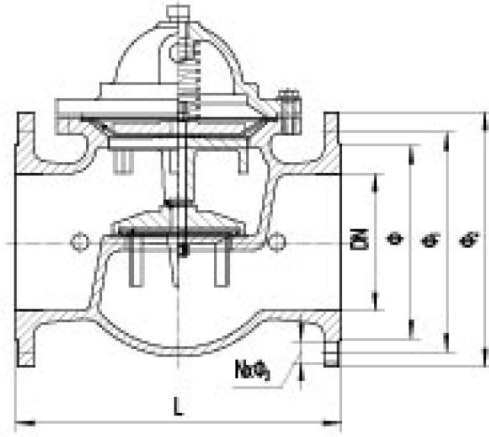

### Specifications

Basic standard
● Flange end: BS4504
Feature
● Nominal Pressure (mpa): 1.6
● Seal test(water): 1.8mpa
● Shell test(water): 2.4mpa
● Suitable temperature: 0~80℃
● Suitable medium: water

### Main parts and materials

Part Name	Material
Body	Ductile Iron
Bonnet	Ductile Iron
Stem	2Cr13
Diaphragm Clamp	Cast Iron
Diaphragm	Rubber
Flat Gasket G	Q235A
Disc	Cast Iron

### Dimensions

DN	L	Φ	Φ1	Φ2	N×Φ3
50	203	99	125	165	4×Φ19
65	216	118	145	185	4×Φ19
80	241	132	160	200	8×Φ19
100	292	156	180	220	8×Φ19
125	330	184	210	250	8×Φ19
150	356	211	240	285	8×Φ23
200	458	266	295	340	12×Φ23
250	530	319	355	405	12×Φ28

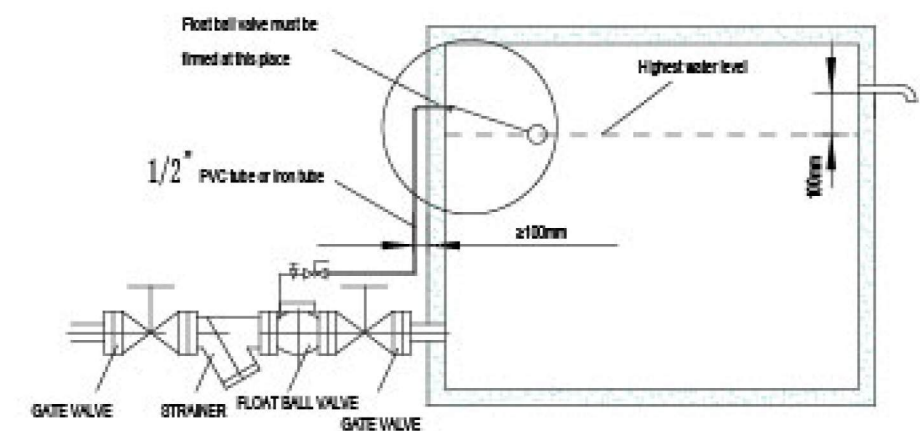
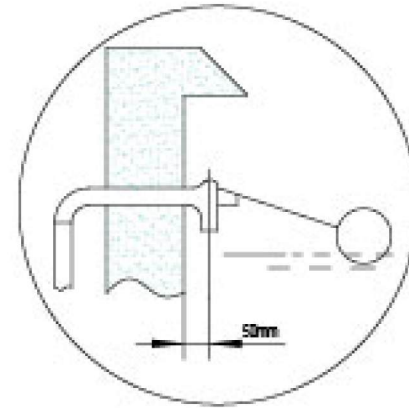

## 200X Pressure Reducing Valve

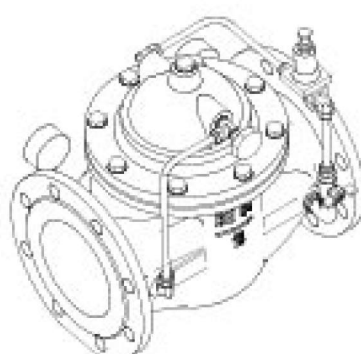
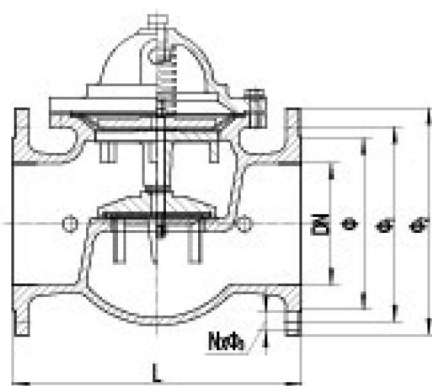

### Specifications

Basic standard
● Flange end: BS4504
Feature
● Nominal Pressure (mpa): 1.6
● Seal test(water): 1.8mpa
● Shell test(water): 2.4mpa
● Suitable temperature: 0~80℃
● Suitable medium: water

### Main parts and materials

Part Name	Material
Body	Ductile Iron
Bonnet	Ductile Iron
Stem	2Cr13
Pressure Reducing Valve	Brass/304
Needle Valve	Brass/304
Ball Valve	Brass/304

### Dimensions

DN	L	Φ	Φ1	Φ2	N×Φ3
50	203	99	125	165	4×Φ19
65	216	118	145	185	4×Φ19
80	241	132	160	200	8×Φ19
100	292	156	180	220	8×Φ19
125	330	184	210	250	8×Φ19
150	356	211	240	285	8×Φ23
200	458	266	295	340	12×Φ23
250	530	319	355	405	12×Φ28

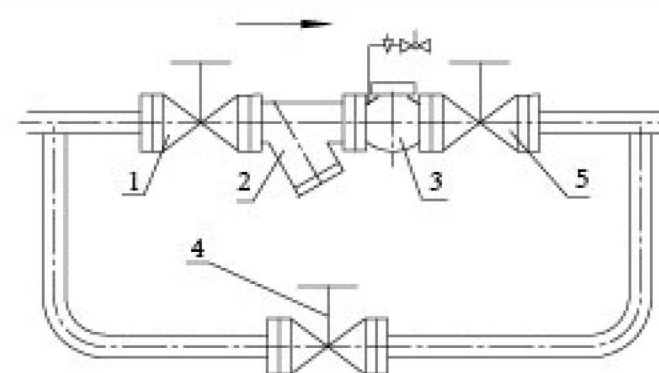

- 1、 4、 5-GATE VALVE
- 2、 STRAINER
- 3、 PRESSURE REDUCING VALVE