

TL-22

2-PC Ball Valve Full Port Flanged Ends

- Material: Cast Iron / Carbon Steel / Stainless Steel CF8 / CF8M
- Size: 1/2"~12"

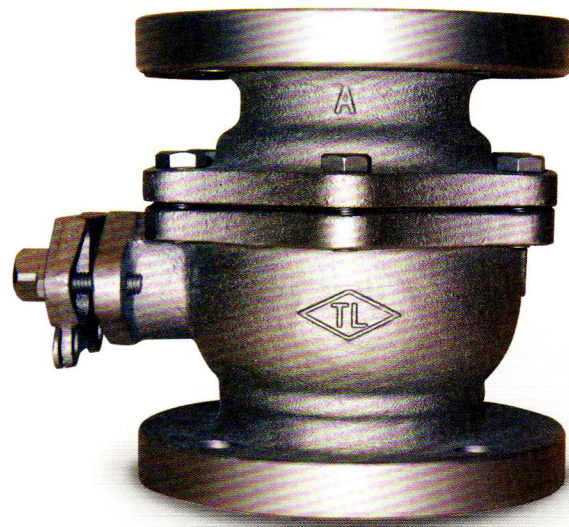
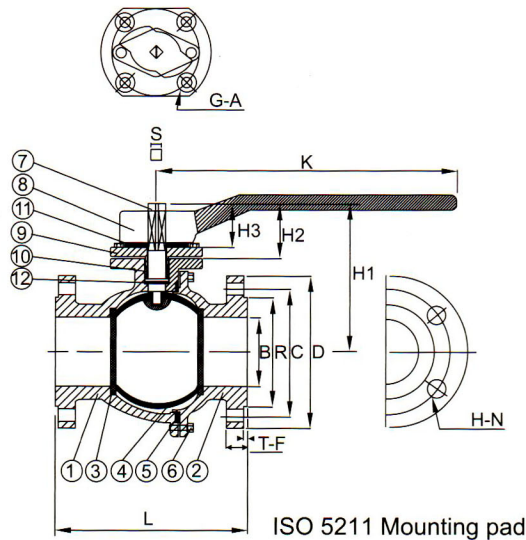

Working Condition

- Working pressure: 10 kg/cm²
- Working temperature: 100°C

Material list

NO	Description	Material			
1	Body	Cast Iron	WCB	CF8	CF8M
2	Body cap	Cast Iron	WCB	CF8	CF8M
3	Seat	TEFLON	TEFLON	TEFLON	TEFLON
4	Ball	SUS 304	SUS 304	SUS 304	SUS 316
5	Joint gasket	TEFLON	TEFLON	TEFLON	TEFLON
6	Gland bolt	SS 41	SS 41	SUS 304	SUS 304
7	Stem	SUS 304	SUS 304	SUS 304	SUS 304
8	Handle	Cast Iron	Cast Iron	Cast Iron	Cast Iron
9	Gland flanged	Cast Iron	Cast Iron	SUS 304	SUS 304
10	Gland packing	TEFLON	TEFLON	TEFLON	TEFLON
11	Travel stopper	SS 41	SS 41	SUS 304	SUS 304
12	Gasket	TEFLON	TEFLON	TEFLON	TEFLON

JIS-10K Dimensions

UNIT : M/M

MM	INCH	L	D	C	B	T	R	F	H	N	K	H1	H2	H3	S	A	G	KG	
																		C.I.	304
DN15	1/2"	110	95	70	16	12	52	1	15	4	175	84	34	22	12	M6	50	3.1	2.9
DN20	3/4"	120	100	75	20	14	58	1	15	4	175	84	34	22	12	M6	50	3.6	3.6
DN25	1"	130	125	90	25	14	70	1	19	4	175	84	34	22	12	M6	50	4.6	4.8
DN32	1 1/4"	140	135	100	32	16	80	2	19	4	175	91	35	22	12	M6	50	6	6
DN40	1 1/2"	165	140	105	40	16	85	2	19	4	230	115	50	33	16	M6	50	8	7.6
DN50	2"	180	155	120	50	16	100	2	19	4	230	120	50	33	16	M8	70	10	10
DN65	2 1/2"	190	175	140	64	18	120	2	19	4	330	140	53	35	19.5	M8	70	15.1	13.6
DN80	3"	200	185	150	78	18	130	2	19	8	330	153	53	35	19.5	M8	70	18.1	16.1
DN100	4"	230	210	175	98	18	155	2	19	8	330	171	53	35	19.5	M10	102	24.6	23.1
DN125	5"	300	250	210	124	20	185	2	23	8	700	227	73	45	25	M12	125	44	41
DN150	6"	340	280	240	150	22	215	2	23	8	700	230	73	45	25	M12	125	66	53.5
DN200	8"	450	330	290	200	22	265	2	23	12	700	297	73	50	25	M12	125	100	91.5
DN250	10"	530	400	355	250	24	325	2	25	12	800	340	85	55	35	M16	140	147	173
DN300	12"	620	445	400	300	24	370	3	25	16	800	382	100	70	35	M16	140	242	217

** Remark: Cast Iron Size from 1/2"-4" without ISO-5211 Mounting pad.