

DR-VALVE

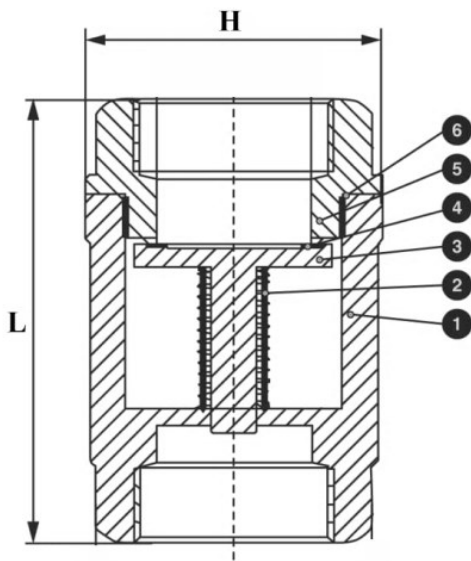

MAIN PARTS AND MATERIALS		
No.	Parts name	Material
1	Body	SS316, CF8M
2	Spring	SS316
3	Disc	SS316, CF8M
4	Seat ring	VITON
5	Cap	SS316, CF8M
6	Seal Gasket	PTFE

SPECIFICATION		
Applicable fluid	Steam, Water, Oil, Air	
Working pressure	Max. 1000psi	
Applicable temperature	Max. 180°C	
Connection method	PT screwed	
Hydraulic test	Body	80 kgf/cm ²
	Seat	70 kgf/cm ²

DIMENSIONS		
SIZE	L	H
8	50	31
10	50	31
15	61	37
20	69	42
25	82	48
32	92	58
40	107	71
50	122	83